



INTEGRITY
MOTOR YACHTS

INTEGRITY 530 GRAND SEDAN



SPECIFICATIONS

Length LOA.....	52'-0" (16.0m)	Water Capacity:.....	250Gal (950L)
Beam.....	15'-4" (4.7m)	Fuel Capacity:.....	528Gal (2000L)
Draft.....	4'-9" (1.5m)	Construction.....	Hand laid fibreglass

*Specifications subject to change without notice dependent on component availability.

INTEGRITY 530 GRAND SEDAN

MECHANICAL EQUIPMENT

- Cummins QSB 6.7L 480hp diesel engines equipped with heat exchangers for freshwater cooling and electronic controls
- Engine overheat and low oil pressure alarms
- Complete engine instrumentation at control station Groco internal seawater strainers
- Racor FG fuel filters
- Fiberglass drip pans under the engine
- S/S 316L prop shaft
- P.Y.I. drip-less shaft seal
- 5 bladed propeller
- S/S 316L rudder shaft
- FRP rudder plate
- Hydraulic wet muffler
- Hydraulic steering
- Engine room blowers & air intake vent
- Superior engine room sound proofing material
- Electric bilge pumps
- Manual bilge pump
- Fuel manifold
- Fuel tanks are of aluminum
- Water tanks are of welded stainless steel
- Sea cocks on all through hulls at or below water line Quick 40L 220VAC hot water heater
- Jabsco 12Vdc pressurized fresh water system

HARDWARE

- Anchor platform with roller
- Bow and stern staffs
- Windlass Quick 1500w
- Cleats 2 bow, 2 amidships, 2 aft with s/s chocks or fair leads
- Manship deck hatch over guest cabin
- Windows aluminum framed with insect screens Selected windows slide, forward saloon window opens Electric Horn
- Stainless steel rub rails
- Bow thruster Quick 10hp
- Stern thruster Quick 10hp
- FRP radar mast
- Door locks on all saloon doors with keys. Deck rails 316 stainless steel
- Transom, Port and Starboard gates
- 3 double arm Windscreen wiper and fresh water washer to 3 front windcreens
- International navigation lights
- Accommodation ceiling lights
- Reading lights in cabins
- Cabin door locks
- Swim ladder

ELECTRICAL SYSTEM & COMPONENTS

- Onan 9kw Generator complete with sound shield, muffler & fresh water cooling & separate starting battery in F.G. battery box
- 3 heavy-duty 200 Amp hour engine starting & lighting batteries in F.G. battery boxes
- Engine batteries parallel for starting
- Customized Paneltronics (or similar) electrical panel utilizes USCG approved circuit breakers and is fitted with polarity indicator light, ship/shore switch, back lighting, integrated AC and 12VDC volt/amp meters and is concealed behind a lockable door with lighting in cupboard
- Wiring color-coded & numbered
- Victron 3000W inverter/charger

- Engine hour meter
- Stereo speakers in each cabin
- Electrical outlets to galley and each cabin
- Ship to shore dock side receptacle with integrated galvanic isolator
- Two shore power

SALOON

- Built in settee lounge /w storage under
- Hi-Lo teak color yacht table which can be converted into a bed
- Bar with bottle storage and glass storage cabinet.
- Teak & holly sole
- Hatch access to engine room with ladder
- Helm station with steering & controls & Instrumentation and chart locker
- Overhead electronics lockers
- Access door to starboard
- Headliner of white acoustic vinyl
- Overhead LED lights 12 volt DC
- All furniture & bulkheads are teak

PILOTHOUSE

- 26" Destroyer wheel
- Helm station centered
- Overhead electronics console
- L shaped dinette behind helm station converts to berth
- Teak and holly sole

GALLEY

- Teak galley unit.
- Electric Hot Plates/ Convection microwave under
- Trash bin
- Double Stainless steel sink with cover & single lever faucet. Under counter 12VDC/220VAC refrigerator
- Drawers and cabinets under counter
- Overhead dish and cup lockers
- Overhang cabinet with glass storage under
- Exhaust blower

MASTER STATEROOM

- Queen size bed
- Side table with drawers
- Wardrobes with auto lights
- Teak & holly sole
- Teak bulkheads & furniture/Vanity with drawers under
- Mirror
- Headliner of white acoustic vinyl Reading lamps swivel type-12 volt DC Overhead lights-12 volt DC

FRONT CABIN

- Island bed with drawers under Wardrobe with auto light
- Teak bulkheads
- Teak & holly sole
- Headliner of white acoustic vinyl. Reading lamps-12 volt DC. Overhead LED light-12 volt DC

HEADS

- Two showers are stall type
- Shower sole of white ceramic tiles with built in automatic drainage system
- Bulkheads covered with white FRP
- Vanity unit fitted with ceramic washbasin in white Corian Single lever shower and sink H&C water faucets
- Teak & holly sole all around

- Mirror
- TMC macerator luxury head with household size bowl
- Exhaust blower
- White FRP headliner
- Overhead lights 12 volt DC
- Fiberglass holding tank w/Y-valve and remote display panel

MISCELLANEOUS

- FRP white color cap rails
- Transom Shower
- 5 coats of varnish
- Anti-fouling paint
- Owner's manual
- All drawers are drop down to lock type. Non-slip deck on front to be plain white shiny The rest to be diamond pattern anti-slip deck

OPTIONS

- Upgrade engine to one Scania 700HP
- Upgrade to 13.5KW generator
- Air Conditioning
- Two shore power
- Corian counter top select
- Trim tabs
- Raymarine electronics
- TV in saloon and cabins
- Salt water deck wash system in the bow deck
- Fresh water deck wash system in the cockpit
- Teak after deck
- Additional engine room sound proofing
- Naiad stabilisers

**Import: Swanta-yachting
Hilversum, The Netherlands
Tel.+31(0)627890535
Email:info@integritytrawlers.nl
www.integritytrawlers.nl**



THE NAME SAYS IT ALL

www.integritytrawlers.nl

*Specifications subject to change without notice dependent on component availability.



Introducing the new

530 GRAND SEDAN

ARRIVING FEBRUARY 2017
LIMITED PRE-ORDERS AVAILABLE

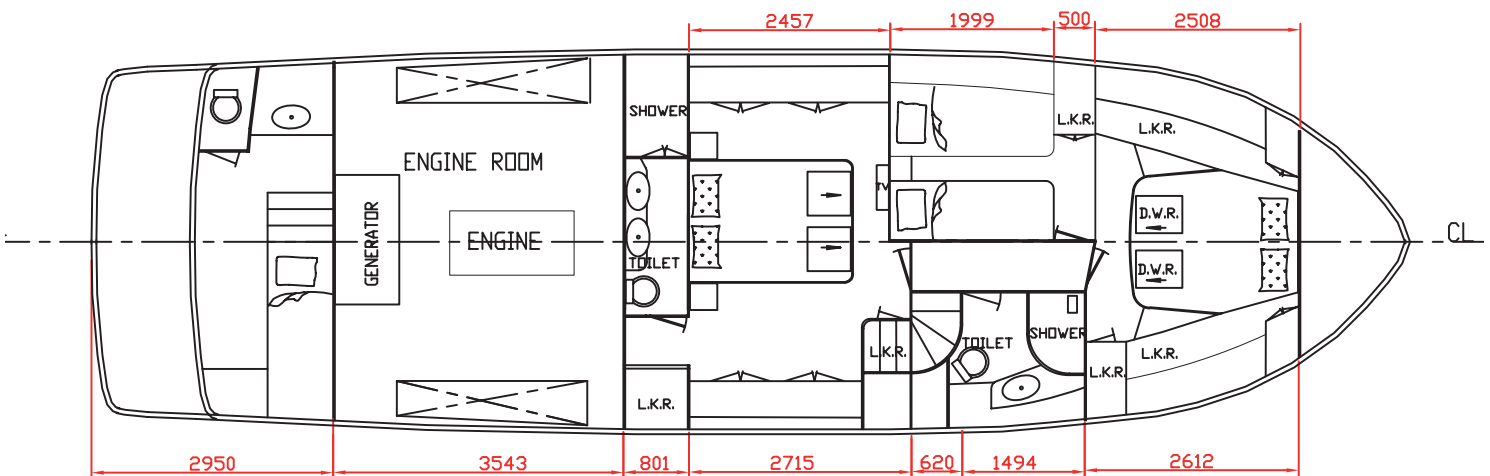
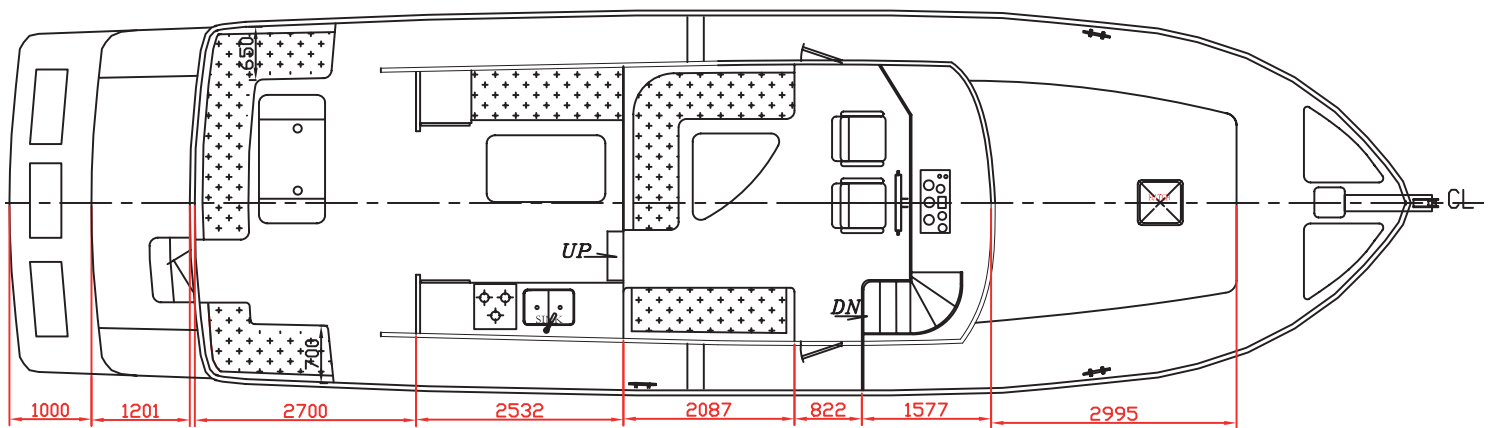

Integrity Grand Sedan 530GS 16.10x4.70x1.50 Meter
Engine 1x Scania 700 HP