



INTEGRITY

The ship for your life

INTEGRITY 380 Flybridge



SPECIFICATIONS

Length 11.70 m
 Beam 4.10 m
 Draft 1.16 m
 Displacement 11.500 kg

Fuel Capacity 1135 Litres
 Water Capacity 530 Litres
 Holding tank 175 Litres
 Construction Hand laid fibreglass

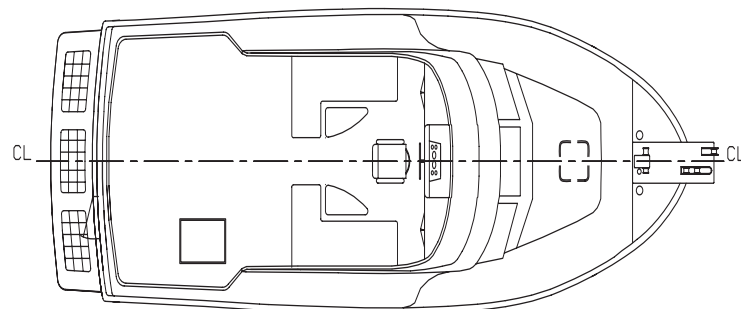
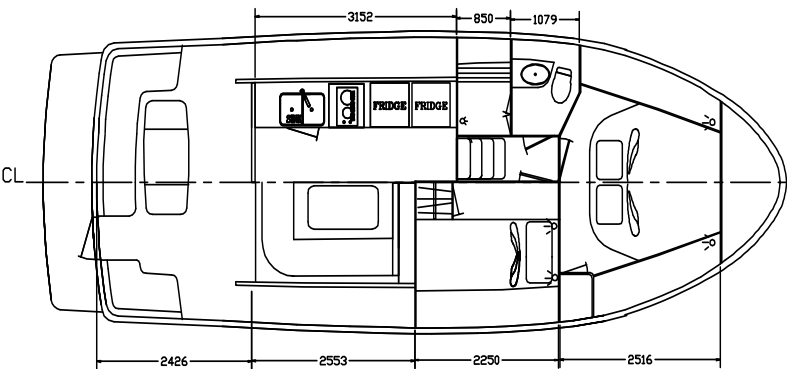

320ES - 350 S - 380 S - 380 F - 440S - 440F - 47XL - 47XL F - 490 GS - 490 RPH

INTEGRITY 380 Flybridge - STANDARD EQUIPMENT

- *JDeere 225HP engine equipped with heat exchangers for freshwater cooling, ZF gearbox
- *Engine overheat & low oil pressure alarms
- *Complete engine instrumentation at control station
- *Groco internal sea water strainer
- *Racor FG fuel filter
- *Drippan under the engine
- *Stainless steel prop shaft
- *P.Y.I.dripless stern gland
- *Right handed bronze propellor 4 or 5 bladed
- *Rudder fibreglass blade/s.s. shaft
- *Hydralift wet box mufflers
- *Hydraulic steering

- *Engine room blower & air intake vents
- *Engine room sound proofing material
- *2x12VDC 1500GPH electric bilge pumps with float switches and manual/auto switching
- *Manual bilge pump
- *Fuel manifold system with dedicated supply, return and bypass valves

- *2xFuel tanks welded stainless steel with built-in sumps hand hole cleanout ports & sight gauges
- *Water tank welded stainless steel with sight gauges
- *2xMorse engine throttle & gear box controls
- *Sea cocks on all through hulls at or below water line
- *Quick 45 litre 240VAC hot water heater

- *Jabsco 12VDC Pressurized fresh water system

HARDWARE

- *Anchor platform with roller
- *Windows in aluminium,selected windows slide
- *Cleats 2 bow,2 midships,2 aft with chocks or fair leads s/s
- *Teakcockpit and swimplatform teak insert
- *Cockpit seating
- *Deck hatch over guestcabin with insect screen
- *Windows fix tint glass
- *Door locks on all saloon doors with keys
- *Horn electric
- *Swim platform and solid "D" section rub rail
- *Deck rails stainless steel & bowstaff
- *Transom & P&S gates
- *Windscreen wipers and fresh water washer to 2 front windcreens
- *International navigation lights
- *Accomodation ceiling lights
- *12VDC reading lights in cabins
- *Cabin door locks etc
- *Transom hot and cold fresh water shower
- *4 step folding s/s swim ladder
- *ladder to flybridge

ELECTRICAL SYSTEM & COMPONENTS

- *40Amp battery charger
- *4 Heavy duty 150A hour engine starting & lightning batteries in FG battery boxes

- *Engine batteries parallel for emergency starting
- *Bonding systems with zinc anode
- *Customized paneltronics electrical panel utilizes approved circuit breakers and is fitted with polarity indicator light,ship/shore switch,back lightning,integrated AC and DC volt/amp meters and is concealed behind a lockable door or a simular main switch panel
- *Wiring colour coded & numbered
- *Engine hour and volt meter
- *Stereo speakers
- *Electrical outlets to galley & each cabin
- *Ship to shore dock side inlet fitting with integrated galvanic isolator (15Amp)
- *Battery selector switch,light/engine

SALOON

- *Hi-Lo table can be made into bed
- *Teak & holly sole floor
- *Hatch access to engine room
- *2xHelm station with 22"steering wheel & morsecontrols & instrumentation
- *Sliding helmdoor
- *Headlining white acoustic vinyl
- *Overhead LED lights 12 volt
- *All furniture & bulkheads are teak or other wood(choice)

GALLEY

- *Electric stove/plates
- *Galley unit with white counter top
- *Stainless steel sink with cover & single lever faucet
- *Under counter 12VDC/240VAC refrigerator
- *Drawers and cabinets under counter
- *Exhaust blower
- * S/S & glass hopper windows

MASTER STATEROOM

- *Island bed
- *Wardrobes with auto lights
- *Teak & holly sole floor
- *Teak or other wood bulkheads & furniture
- *Heading white acoustic vinyl
- *Reading lamps swivel type 12 volt
- *Overhead LED lights 12 volt

HEADS/SHOWER ACCESS

- *Shower sole with built in automatic sullage system.Head and shower separate
- *Vanity unit fitted with s/s or ceramic wash bassin in white counter top
- *Single lever shower & sink H&C water faucets
- *Mirror & Skylight
- *Jabsco macerator, with elec. toilet
- *Exhaust blower
- *Overhead LED lights 12 volt
- *175 Litres holding tank with Y-valve,
- *Jabsco macerator pump,deck discharge outlet, inspection port to tank in engine room and remote "full " display panel in head.

- *Hull bottom antifouled
- *GRP cap rails
- *Emergency tiller
- *Aft deck seats with cushings and storage under
- *Owners manual
- *Flybridge with seating/cushions

OPTIONS

- *search light
- *Bow & stern thrusters
- *Deck wash fresh water mounted at aftdeck
- *Wifi antenna &TV Glomex
- *Webasto heating
- *Microwave

- *Inverter
- *Gas cooker
- *Corian counter tops
- *Fusion soundsystem &TV
- *Teak deck
- *Anchor electric winch
- * CQR Anchor +chain stainless S
- *4KW Onan generator
- * Navigation electronics
- *Double glazing
- *Double Racor fuelfilters
- *Upholstery in leather

SIDE CABIN

- *Bed 2.20x1.40m
- *Wardrobe with auto lights
- *Teak & holly sole floor
- *Heading white acoustic vinyl
- *Reading lamps swivel type 12V
- *Overhead LED lights 12 volt

DEALER

